

## Mounting-instruction, User - and maintenance-handbook

for the series NO FRILLS COMPACT models 400-600 230 volts 50 Hz



PureWater. H. Fehlemann - Desalination

Bodelschwinghstr. 37

33142 Büren Germany

Tel: +49 (0) 2112936944

Fax: +49 (0)2112936945

Mobile: +491713846092

Internet: [www.watermaker.de](http://www.watermaker.de) e-mail: [purewater@watermaker.de](mailto:purewater@watermaker.de)



## **Your Freshwater-Source**

We are happy that you decided in favor of one of our reversion-osmosis-installation (RO unite) and you greet in the growing circle of the users of desalination-installations.

We will do everything in order to satisfy you also after your purchase.

This handbook contains, exact instructions, as you fit in your installation, use it and keep it maintained.

If you should have further questions in addition, you don't hesitate to call us.

In order to gain an optimal performance and a long lifespan of your installation, you read alertly through this handbook before the mounting; if you should require further help, you let it know us.

PureWater – Desalination

# INVOICE

System-bases.....	1
Performance data.....	2
Membrane-Performance.....	2
Electric connection-values.....	3
Pressure regulation.....	4
Before mounting. ....	5
Description of the individual parts. ....	6-7
Quality Monitor.....	8
Motor and pump. ....	9
Factors affecting Temperature and Pressure.....	10
Mounting and Starting.....	10-11
Flow-diagram. ....	12
Mounting and connections.....	13
Pressure Regulator.....	13
Electrical installation.....	14
Starting the System.....	15-16
Maintenance.....	16
How to Flush.....	17
Cleaning.....	18
Storage.....	19
Membrane Change.....	20
Manufactures Literature.....	21-23
Manufactures Literature.....	22
Logbook.....	24
LP Pump.....	25

## **System-bases**

### **Introduction into the reversion - osmosis**

Reverse-osmosis is a process, with which a membrane divides one water-flow in two water flows. One part is fresh-water and amounts about 7-10 percent of the entire water-quantity, the other flow is concentrated saltwater, which is washed away. Since saltwater is a solution of H<sub>2</sub>O and different solved materials (salt), the membrane acts like a filter. In order to be able to remove these solved materials from the water, the pores of the membrane must be smaller than the solved materials that should be taken away. The pores of a membrane are so small that they can be seen only by one electron microscope. (0,0001 microns, that means, that the sea-water must be pressed through the membrane. This pressure must have the strength of 800 Psi (56 bar) approximately. How high the current pressure must be exact, is a result from the water-temperature and the salt content of the water.

This temperature / pressure-relationship later will be explained later in this handbook.

See chapters: Temperature - Pressure - Correction.

As you know, each filter can become blocked or damaged. A reverse-osmosis-membrane is no exception. Your System is designed that surplus particles are rinsed with the Brine flow.

Nevertheless, there are conditions, which contaminates, blocked or damage the membrane. With regular maintenance, as it is described in this handbook, the possibility of a failure of a membrane can be minimized and costly substitute be avoided. Regular maintenance is comparatively affordable, gets the effectiveness and extends the lifespan of the installations.

## Performance Data

### Membrane-performance\*

Model	gallons per hour	liter per hour
200 GPD	8,30 GPH	31,41 LPS
400 GPD	16,60 GPH	62,83 LPS
500 GPD	20,80 GPH	78,20 LPS
<b>600 GPD</b>	<b>25,00 GPH</b>	<b>94,50 LPS</b>
<b>800 GPD</b>	<b>33,33 GPH</b>	<b>126,00 LPS</b>
1300 GPD	54,20 GPH	205,14 LPS
1800 GPD	75,00 GPH	283,81 LPS
2000 GPD	83,33 GPH	315,40 LPS
3000 GPD	125,00 GPH	473,12 LPS

Salt-Rejection = Minim. 99,2%

Water-quality = above WHO standard

•Sea-water-temperature, pressure and salt content have strong influence on the performance and quality of the product-water. Details you find in the chapter Operation.

### Test-conditions

Pressure	800 PSI
Sea-water-temperature	25° C
Salinity	35,000 PPM (parts of million))

### Pump-performance

Operating-pressure 700 - 1000 PSI

### Total Flow

200-400 GPD systems	2,3 GPM (9L/h)
600-1000 GPD systems	2,9 GPM(11L/h)

## **NO FRILLS 400-600 Guide**

---

### **Electric connection-values**

#### **230-volt**

<b>SERIES</b>	<b>Ampere</b>	<b>KILOWATT</b>
NO FRILLS 500 GPD	7	1,1
NO FRILLS 600 GPD	9	1,5
NO FRILLS 1000-1800 GPD	16	2,2

### **Electric wiring**

The connection should be carried out by a qualified electrician.

We recommend a relay into the on-circle to placed, because the contacts of the counter can burn otherwise. High pressure-pump and low-pressure-pump can become interconnected.

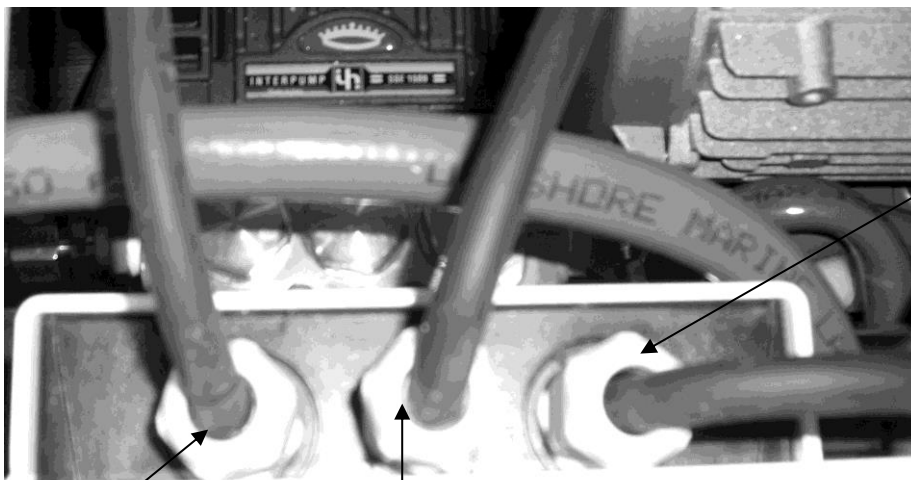

**Power Cable**  
230V 50 Hz

**Boostpump (LP Pump)**

**Cable Hp Pump**

## NO FRILLS 400-600 COMPACT Guide

The NO FRILLS 400/600 semi modular is delivered in following implementation.

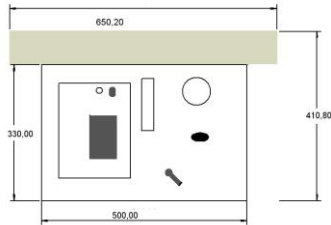

Frame front view

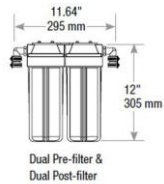

Dual Pre-Filter

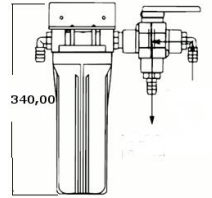

Fresh Water Flush (FWF) system

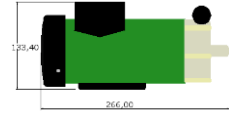

LP Pump

+ PH Stabilizer

## Pressure Regulation and Flow distribution

Start Switches  
LP and HP Pump  
Product Flow Meter

Quality Monitor

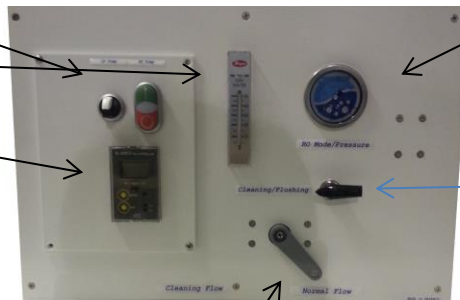

Pressure indicator

High Pressure Bypass  
Valve Position :  
Cleaning/Flushing  
**NO Pressure**

CLEANING VALVE: Position: **NORMAL FLOW**: for desalination and flushing. Brine Flow over board. Position: **CLEANING flow**: for cleaning and preservation. The flow is returned to the LP PUMP or to the "T" at the Fresh water flush system. See flow diagram.

### **Before mounting!!**

**Please pay attention to the following points before you fit in your NO FRILLS installation and take in operation!**

1. The installation should be taken in operation within 12 months after delivery.
2. The installation should about every 7 days, in very hot areas, every 3 days, operated with sea water or flushed with fresh-water.
3. If the installation is for a long time out of order, it should at the latest after 12 months flushed and preserved again.
4. Never operate the system in harbors or in areas where fuel and oil is in the sea-water.
5. If you use the system in fresh - or brackish water the operating-pressure must be adjusted, that the output of fresh water is within the operating limits.
6. Protect the installation from freezing.
7. Don't let the membrane dry out. If you take out the membrane for any reason, it has to be sealed immediately.
8. **The sea-water- inlet must be shaped so that the sea-water is pressed in during cruise.**

### **Attention!!**

**The quantity of the produced drinking water is very strong dependent on the temperature of the sea-water. All accomplishment-statements are based on a temperature of the sea-water of 25°C. Per 1°C under 25°C, the production loses 3 percent of performance.**

**As well, the salinity of the sea water is a factor. Higher salinity - lower performance.**



## **NO FRILLS 400-600 framed Guide**

---

### **The general scopes of the NO FRILLS desalination-installations.**

The NO FRILLS RO systems are laid out according to the last realizations of the reversion-osmosis-technology. These installations enjoy ever more severe popularity with Cruisers, sport-fishers and on boats, where mounting space is limited.

The NO FRILLS are simple to use and uncomplicated in maintenance.

The NF 400 produces about. 62 liters / h, the NF 600 produces, about. 94 liters / h. See the reduced performance with temperatures under 25°C and higher salinity.

### **2.2 descriptions of the individual parts**

#### **The 230V LP Pump.**

The LP Pump is required to the circulating the sea-water if the high-pressure-pump is built-in at or over the waterline. The booster-pump must be installed below the waterline. The booster-pump supports the start-process, trapped air is fast removed.

#### **Hand-water-test-appliance (Optional) Not required on COMPACT Models**

The hand-water-Tester measures how much ppm of the TDS still is in the water. The value from the World-Health-Organization, WHO, for good drinking water is 500 ppm.

ppm = parts per million TDS (total dissolved Solids)

#### **Pressure gauges**

The pressure gauge shows how much pressure the high pressure-pump delivers. The work-area is between 800 and 950 psi.

#### **High pressure-pump**

The high pressure-pump pumps waters through the membrane

#### **Flow meter**

How much drinking water is produced in the hour shows the flow-meter.  
(In U.S. gallons per hour) 1 U.S. Gallon = 3.78 liters.

#### **Pressure Regulator**

The pressure control allows the operator to regulate the pressure. 800 psi are normal.

#### **Sea-water-filters (option)**

The sea-water-filter keeps back coarse particles and spares the booster-pump and the pre-filter consequently.

#### **Pre-filter**

The pre-filter has a permeability of 10/5 microns and filters the fine particles. The 10µ Filter is a carbon filter.

#### **Sample Valve (option) Not required on COMPACT Models**

The sample-valve enables to take a water-test directly at the exit of the system. This is to the control the water so that one can prevent the influx of bad water.

**Cleaning-valve**

This valve enables, either a flow over board, or a recirculation for cleaning and preservation. See flow diagram.

**Fresh-water – flush system**

The fresh-water – flush system provides flushing the system, when not in use, with fresh water, just with a turn of the handle at the selector valve. The build in changeable carbon filter cartridge prevents that chloride comes to the membrane. The handle must be installed below the waterline in any case. Flushing the system extends the lifetime of the membrane and is used for short time storage. (up to 10 days )

**POS: Desalination**

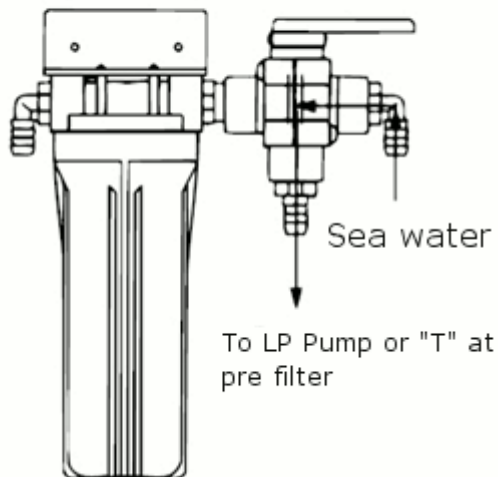

**POS: Fresh water flush**

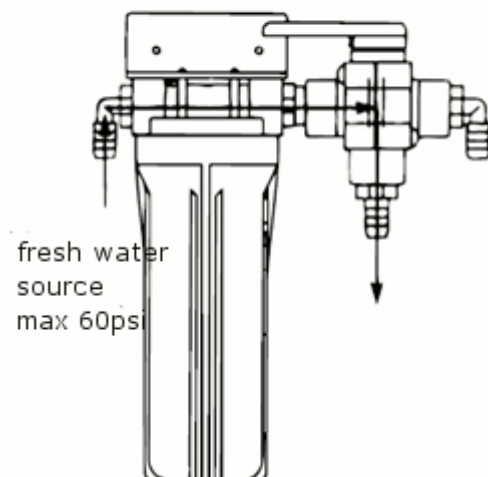

**Note!!**

If you install the boost pump direct after the sea cock, the “T” for the return cleaning line is mounted at the valve of the fresh water flush system. (FWF system)

## Quality Monitor (COMPACT and COMFORT Versions)

The Quality Monitor shows the quality of the product water in PPM TDS (Part per Million Total dissolved Solids) The Quality Monitor is activated with LP Pump switch.

When starting the system the quality is always for a short period ( 30-45sec) high salinity. Shortly the monitor starts to count down. As soon as the quality reaches the pre-set value(factory set point is 500PPM) the water is produced into the tank.

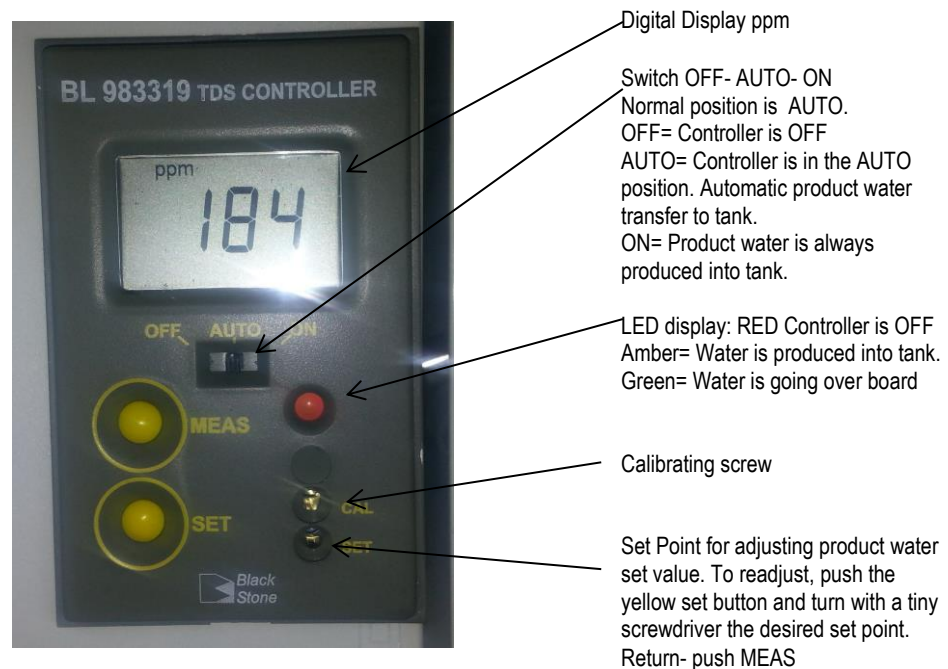

The controller is activating a diversion valve to control the destination of the product water. The diversion Valve is located at the right side of the Main control panel. There is an emergency gray button, to override the valve. Only to be used, when the controller is not working. Push and turn to the right to lock.

## Motor and HP Pump

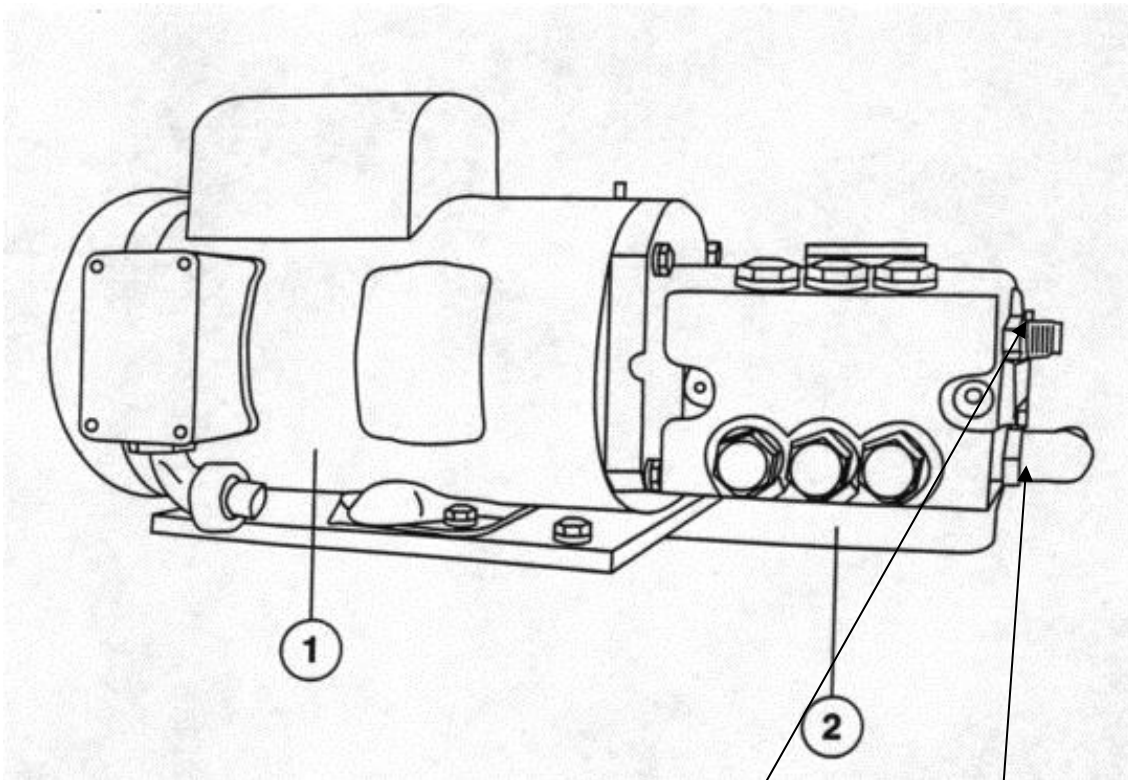

1 Motor

See water inlet

High pressure connection

2 High pressure pump

**Attention: Before starting the Pump, change the red safety transportation cap on top of the pump - to the yellow cap with the mark: OIL. This will provide crank case ventilation.**

**FACTORS AFFECTING PERMEATE PRODUCTION  
VARIATIONS IN TEMPERATURE, PRESSURE, AND SALINITY**

The following table illustrates how the quality and quantity of permeate produced by a RO system is affected by changes in temperature, salinity and pressure:

<b>With constant</b>	<b>and increasing</b>	<b>TDS</b>	<b>Capacity</b>
Salinity and pressure	Temperature	increasing	increasing
Temperature and pressure	Salinity	increases	decreases
Temperature and salinity	Pressure	decreases	increases

\* If the feed water salt concentration decreases, the product water flow rate should not be allowed to increase more than 20% above rated flow. Feed pressure may need to be lowered to maintain rated flow in brackish water or tap water applications.

\*\* Feed pressure shall not be increased above 950 psi.

The RO system can be adjusted to maintain a constant permeate output when feed water temperature and salinity is other than nominal. The operator can do this by controlling system pressure manually via the backpressure regulation valve located in the system brine piping. As permeate flow decreases, the operator can throttle the pressure regulation valve closed to increase system pressure. This, in turn, will increase the permeate output and mitigate the effect of a decrease in temperature or an increase in salinity. Conversely, the operator can open the pressure regulation valve to reduce pressure and permeate flow in areas of excessively high temperature or low salinity.

**IN FRESH OR BRACKISH FEEDWATER CONDITIONS, MAKE SURE TO REDUCE PRESSURE BY TURNING REGULATOR. SET PRESSURE SO, THAT PRODUCT FLOW IS NO MORE THAN 120% OF DESIGNED FLOW; TO PREVENT MEMBRANE DAMAGE.  
TEMPERATURE CORRECTION FACTOR**

As previously described, the output capacity of any RO unit is highly dependent on feed water temperature. In order to quantify this relationship, operational data has been utilized to develop Temperature Correction Factors (TCF). The TCF (which is compensated to 25°C/77°F) is used to determine what part of any change in system output flow is due to variations in feed water temperature alone. This, in turn, allows the operator to establish the baseline flow for a given temperature, allowing more accurate troubleshooting. The procedure for calculating the TCF and the temperature compensated flow is as follows:

- 1) Measure raw water temperature.
- 2) Determine the corresponding correction factor from Table 3.2 based on the measured temperature.
- 3) Note the product flow rate at the Product Flow meter.
- 4) Multiply the measure (uncorrected) product flow meter flow rate by the correction factor from Table.

## NO FRILLS 400-600 framed Guide

---

### Example:

Raw water temp: 15°C

TCF: 1.47

Uncorrected product flow: 12.75 (gph)

Calculation:  $12.75 \times 1.47 = 18.743$  (gph)

Corrected product flow: 18.7 (gph) This is the normal flow for a NF500

°C	Factor	°C	Factor	°F	Factor	°F	Factor
1	3.64	26	0.97	34	3.47	84	0.88
2	3.23	26	0.94	36	3.18	86	0.82
3	3.03	28	0.91	38	3.18	88	0.79
4	2.78	29	0.88	40	2.68	90	0.79
5	2.58	30	0.85	42	2.47	92	0.77
6	2.38	31	0.83	44	2.29	94	0.75
7	2.22	32	0.80	46	2.14	96	0.73
8	2.11	33	0.77	48	2.01	98	0.70
9	2.00	34	0.75	50	1.88	100	0.68
10	1.89	35	0.73	52	1.77	102	0.65
11	1.78	36	0.71	54	1.68	104	0.63
12	1.68	37	0.69	56	1.59	106	0.61
13	1.61	38	0.67	58	1.51	108	0.59
14	1.54	39	0.65	60	1.44	110	0.57
15	1.47	40	0.63	62	1.38	112	0.55
16	1.39	41	0.61	64	1.30	114	0.53
17	1.34	42	0.60	66	1.24	116	0.51
18	1.29	43	0.58	68	1.17	118	0.49
19	1.24	44	0.56	70	1.12	120	0.47
20	1.19	45	0.54	72	1.08	122	0.45
21	1.15	46	0.53	74	1.05		
22	1.11	47	0.51	76	1.02		
23	1.08	48	0.49	78	1.00		
24	1.04	49	0.47	80	0.93		
25	1.00	50	0.46	82	0.90		

(

Flow diagram: Installation of the FWF System above WL

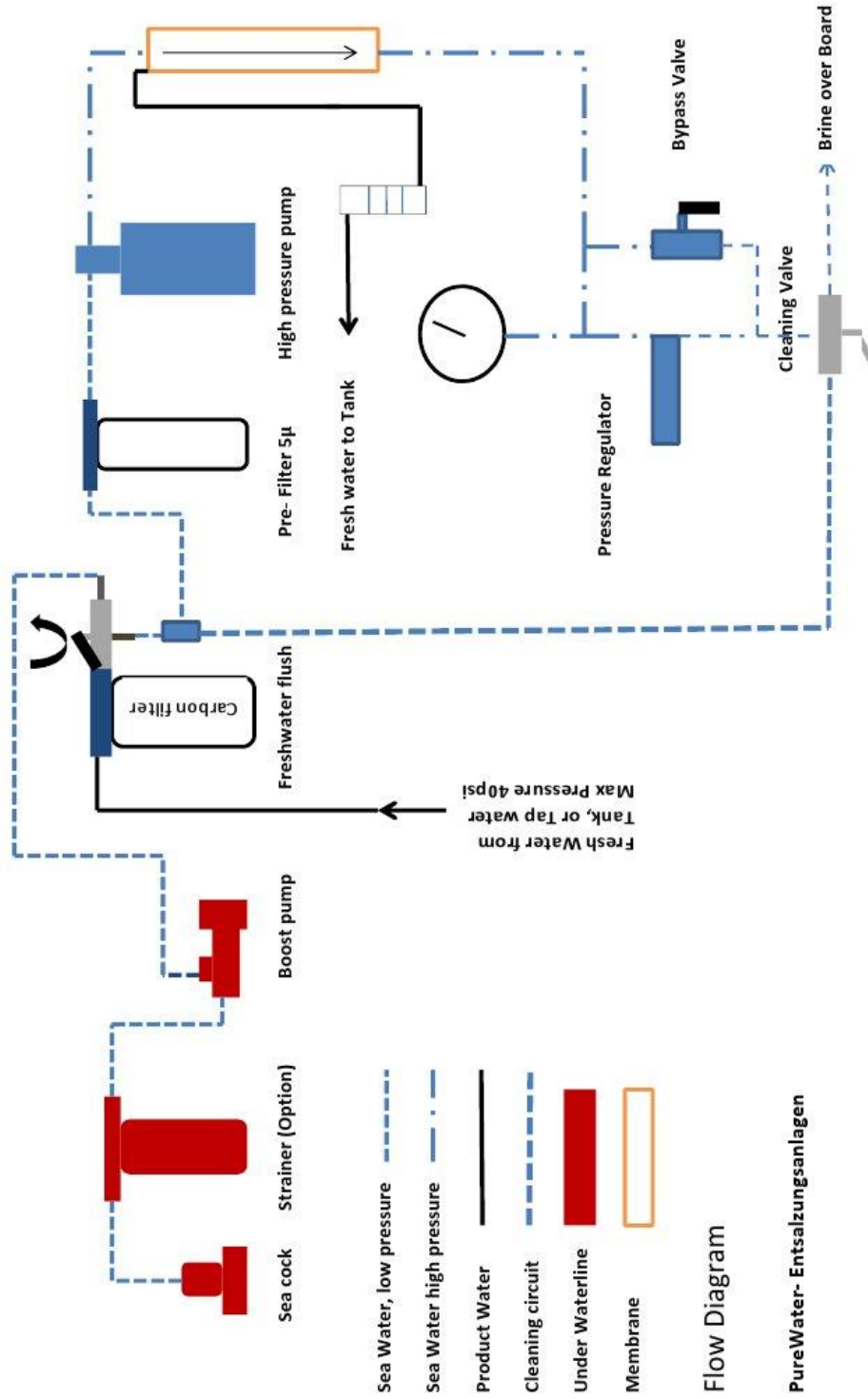

## Mounting and connections

On the picture below, you see the manifold with the connections.

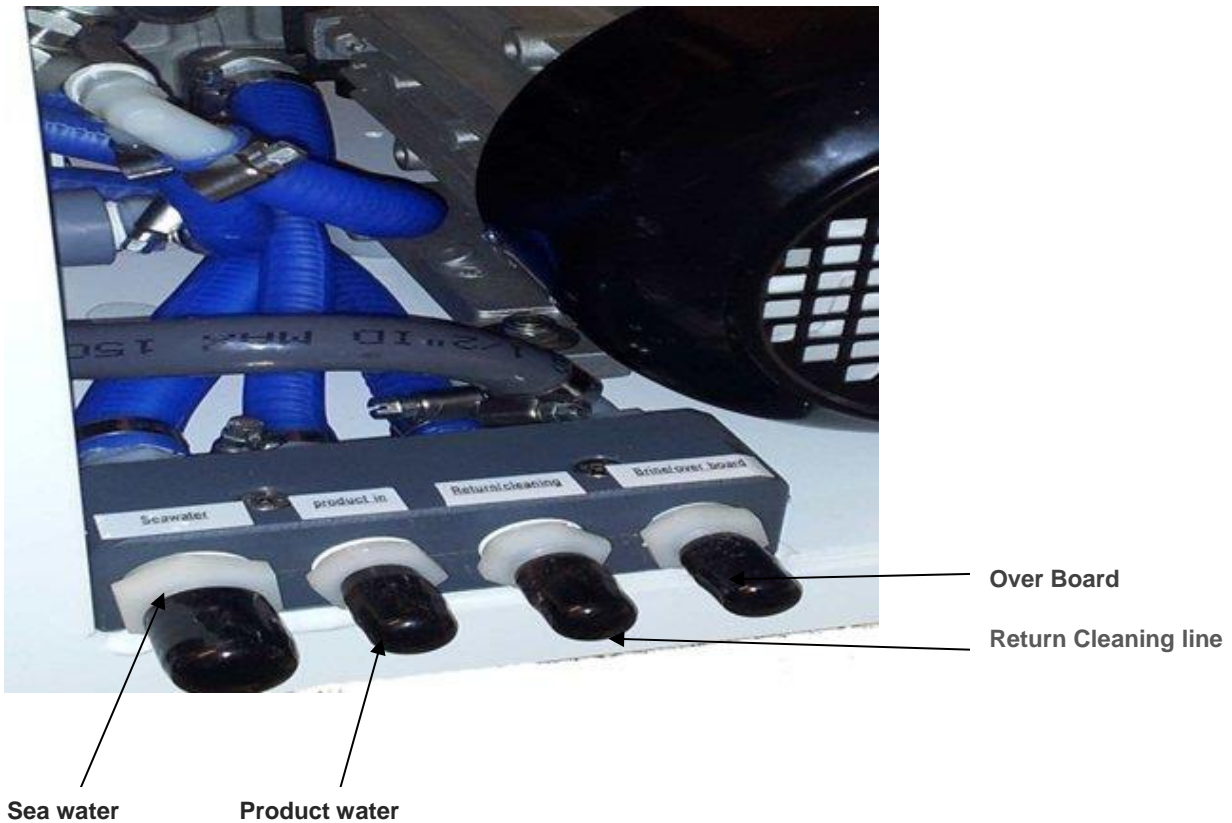

**Return line for cleaning:** For units **with** LP Pump (Boost pump) the return line is a ½” hose to the pre mounted “T” at the inlet of the boost pump. For units **without** LP pump, or LP pump mounted direct after the sea cock, the return line has to be mounted at the “T” on the fresh water flush system.

## Pressure Regulator

The pressure regulator is a fixed set up type; however, it can be adjusted. The regulator is factory set to 800psi (56bar). It might be necessary to adjust. That depends on salinity and temperature. Refer to Temperature and salinity adjustment. But anyhow, the unit will operate with 800psi pressure within the operational limits. See picture below for location of the pressure regulator. Use a key to adjust.

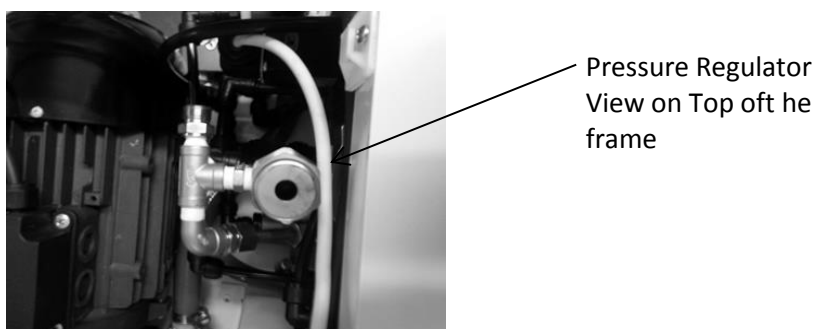



## **TO CONNECT THE ELECTRICAL**

**TURN OFF ALL ELECTRICAL POWER FOR USE WITH THE RO UNIT PRIOR TO CONNECTING TO THE RO POWER SOURCE. FAILURE TO DO SO MAY RESULT IN SERIOUS INJURY OR DEATH TO PERSONS HANDLING THE UNIT.**

**NOTE:** Adhere to all electrical codes and regulations governing the installation and wiring of electrical equipment. Typical codes specify the type and size of conduit, wire diameter, and class or wire insulation depending upon the amperage and environment.

**NOTE:** The power supply should always be of greater service rating than the requirements of the RO unit. This will assure proper voltage even if power supply voltage is slightly less than required.

**Never connect the RO unit to a line that services another electrical device.  
THE RO UNIT SHOULD HAVE ITS OWN INDEPENDENT POWER SUPPLY.**

**NOTE:** We recommend use of a **15 amp** fuse or circuit breaker for **230 Volts AC** units.

For 380-400V units you can use the same breaker size, however the current is less than by 230V.

Actually there is no preferable turning direction and there is no limitation for the pump, however, the best direction is, if you look at the back side of the Motor, left turns. You can see it at the fan. On 380-400V three phase models, the turn direction can be changed by interchange either L connector.

## **Starting the System**

Step 1: Verify all power switches and power sources are in the **OFF** position.

Step 2:

Turn the High Pressure Bypass Valve (Black Valve) to **CLEANING/FLUSHING POSITION**.

This procedure allows release of the high pressure air trapped within the system.

Verify the Cleaning Valve (Grey Valve) is positioned to **NORMAL FLOW** discharge. Also check the grey Freshwater Flush Valve is positioned for seawater intake, **NOT** freshwater.

### **FAILURE TO OPEN THE HIGH PRESSURE BYPASS VALVE, WHICH IS REQUIRED TO RELEASE ANY TRAPPED AIR, COULD RESULT IN HYDRAULIC SHOCK TO THE SYSTEM.**

Step 3: Verify the seawater intake is open at the through-hull. This allows the feed seawater to flow into the unit.

Start-up time can be expedited by filling the pre-filter housing with non-chlorinated freshwater, before the RO unit is turned on.

Step 4: Switch **ON** the breaker at main breaker panel to power up unit.

Step 5: Upon start-up inspect all plumbing connections in the unit for leakage. Varying temperatures during shipment may cause plumbing connections to seep when starting the RO unit for the first time. Secure the unit and repair any leaks before proceeding. Once the leaks are repaired, open the raw water source and restart the unit.

Step 6: Observe the Brine Flow over board, to ensure all air and bubbles exited the RO system before proceeding to next step.

Step 7: Gradually turn the High Pressure Bypass Valve (Black Valve) to **PRESSURE** position. The pressure gauge should steadily rise to a reading of 800 psi.

Step 8: Observe the system pressure on the High Pressure Gauge. During RO production, the indicated pressure should be at 800-850 psi.(depending on Seawater temperature) If the pressure reading is not at 800 psi, adjust the pressure regulator at the back side of the control panel.

**NOTE: If the RO unit is used for other than seawater purification (in freshwater or brackish water applications), reduce pressure as necessary to achieve product flow no greater than 120% of design flow to avoid membrane damage.**

**RO pressure production should NEVER EXCEED 950 psi, doing so risks damage to RO unit which would VOID factory warranty.**

Step 9: Taste the water quality or test it with a hand-held test meter to determine water quality. If quality is good allow the water to flow into the Tank.

Step 10: Check the RO unit for water leakage periodically at the initial start-up. Observe Product Flow meter.

Record the product flow after 48 hours of operation (use the sample log sheet provided ).

### **4.2 TO SHUT DOWN UNIT**

Step 1: As the RO unit operates, turn the High Pressure Bypass Valve (Black Valve) to **CLEANING POSITION**

(Counter-clockwise), when RO unit is running. This will release the high pressure within the RO system.

Step 2: Turn **OFF** your power at the control box.

The RO unit may be left in this “stand by” condition with the seawater for up to seven days or three days

in hot, tropical climates. If the RO unit will be out of service for extended time periods, please refer to the Maintenance section of this manual.

## MAINTENANCE

The service life of most system equipment is directly related to the raw water inlet conditions. Improper maintenance will also significantly reduce the life expectancy of the major unit components (such as the membranes, filters and pumps) as well as the reliability of the unit as a whole. Under normal conditions, and with proper maintenance, a reverse osmosis membrane (which is the major consumable item) should have an effective service life somewhere between 4 and 6 years.

**NOTE: The RO unit must be cleaned when product water output drops below 5 GPH or when production output drops by 20%.**

**Table 5.1: Maintenance Task Chart.**

	Daily	Weekly	Monthly	Quarterly	Semi-Annually	Annually	As Required	Labor Hours (approximate)
Clean/inspect micron prefilter			•					0.5
Replace filter(s)*				•				0.5
Clean membranes							•	2.0
Replace Membranes							•	1.0
Check pump oil level			•					0.1
Change pump oil**						•		0.5

 Table 5.1: Maintenance Task Chart.

\*\* Change pump oil after first **50** hours of RO use. After the first oil change at 50 hours, change the pump oil every **500** hours thereafter or once annually which ever interval comes first.

## FRESHWATER FLUSH / SHORT TERM STORAGE

Ideally, the No Frills performs optimally when the RO unit is used regularly. The likelihood of bacterial and biological growth in the membranes increases, when stagnant seawater (in extended periods) is in contact with the membranes. A freshwater flush procedure is necessary to prevent clogging and growth of organic contaminants in the RO system and its membranes. This method pushes out older stagnant seawater (saltwater) out of the membranes and replacing it with freshwater (non-saltwater), leaving less chance of fouling the membranes. The freshwater flush procedure should be used when the unit will be placed idle or in “stand by” condition for more than several days **OR** idle for three days in hot, tropical climates. Although they do not attack the membranes or other system components directly, high concentrations of biological matter can block enough of the product water channels to cause a reduction of as much as 40% of the total system capacity. **PERFORM A FRESHWATER FLUSH TO THE RO UNIT WITH NON-CHLORINATED FRESH WATER**

**ONLY. EXPOSING THE MEMBRANES TO CHLORINATED WATER WILL CAUSE IRREVERSIBLE DAMAGE AND VOID THE RO UNIT WARRANTY. THE FRESHWATER FLUSH SYSTEM USES A CARBON FILTER INLINE BEFORE SYSTEM TO CONSUME THE CHLORINE THAT MAY BE PRESENT FROM THE DOCK WATER.**

## **TO FLUSH THE *NO FRILLS* UNIT**

- Step 1: Verify all power switches and power sources are turned **OFF**.
- Step 2: Turn **ON** your water pressure and water maker breakers on main electrical panel. Turn the High Pressure Bypass Valve to **CLEANING/FLUSHING** (ensuring zero pressure in system). Verify the gray Cleaning Valve is positioned to **NORMAL FLOW** position.
- Step 3: Turn the gray Freshwater Flush Valve to **FRESHWATER** position.
- Step 4: Turn the switch at the control panel to **ON**
- Step 5: Verify the freshwater supply pressure does not exceed 35 psi.
- Step 6: After flushing the unit for two minutes, turn the switch at the control panel to **OFF**.
- Step 7: Turn the gray Freshwater Flush Valve to **SEAWATER** position. Leave RO unit in standing condition, for up to three weeks. Then re-flush or preserve.
- Step 8: To restart the **NO FRILLS**, refer to instructions: **TO START THE NO FRILLS UNIT**.

## **CHEMICAL CLEANING PROCEDURE**

The RO unit must be chemically cleaned when product water output drops below 80% of original production. The frequency of this occurring will vary greatly upon feed water. Fouling odor from the membrane will naturally occur during regular usage of the RO unit. The fouling odor will progress without proper cleaning of the membranes, therefore reducing the efficiency of the RO unit.

**THE USE OF CHEMICALS OR CLEANING METHODS OTHER THAN THOSE OUTLINED IN THIS MANUAL WILL VOID THE RO UNIT WARRANTY. NON-IONIC SURFACTANTS USED FOR MEMBRANE CLEANING OR ANY OTHER CHEMICALS NOT APPROVED IN WRITING BY PUREWATER, WILL VOID THE RO UNIT WARRANTY.**

**CLEANING CHEMICAL #1 IS AN ALKALINE DETERGENT, USED TO REMOVE OIL, GREASE, BIOLOGICAL MATTER, AND GRIME FROM THE SURFACE OF THE RO MEMBRANES. SEE WARNING LABEL ON SIDE OF PACKAGE AND OBSERVE ALL SAFETY PRECAUTIONS ON LABEL.**

**CLEANING CHEMICAL #2 IS AN ACID, A MINERAL SCALE REMOVER. SEE WARNING LABEL ON SIDE OF PACKAGE AND OBSERVE ALL SAFETY PRECAUTIONS ON LABEL.**

**NOTE: All cleaning and preservation procedures can be done with either NON-CHLORINATED freshwater to optimize performance of cleaning process, or see water.**

**NOTE: You should allow your unit's product water to run and drain for the first 30 minutes after cleaning or upon start up after preservation.**

## **CLEANING STEPS FOR CHEMICAL #1 AND #2**

### **Single Use Cleaning Cartridges**

Step1. Prior cleaning the RO perform a fresh water flush to the system. Turn the handle at the freshwater flush system to SEA WATER operation to stop the fresh water flow.

Step2. Remove the 5 micron filter from housing

Step3. Place cleaning filter #1, blue stripe, into filter housing and close it.

Step4. Place High Pressure Bypass valve in Cleaning pos.

Step5. Turn Cleaning Valve in Cleaning Pos.

Step6. Start the RO Unite an let it run for 30 Min.

Step7. Stop the RO system and turn the cleaning valve to NORMAL FLOW. Then flush the system with fresh water.

Step8. Place the Cleaning Filter#2, red ring, into the filter housing and start with Step4 to Step7.

Step9. Place a new 5 micron Filter into the housing.

### **Powder Form**

Step1. Prior cleaning the RO perform a fresh water flush to the system. Turn the handle at the freshwater flush system to SEA WATER operation to stop the fresh water flow.

Step 2. Place 10 TBSP of #1 into the filter housing and fill with clean water.

Step3. Crystals need to be completely dissolved before proceeding to next step. Screw housing back into place.

Step4. Place High Press. Bypass in Cleaning pos.

Step5. Turn Cleaning valve into cleaning.

Step6. Start the RO Unite an let it run for 30 Min.

Step7. . Stop the RO system and turn the cleaning valve to NORMAL FLOW. Then flush the system with fresh water.

Step8. place 10TBSP of chemical#2 into the filter housing and repeat the Step3 to Step7.

## **LONG TERM STORAGE / PRESERVATION PROCEDURE**

During periods when the RO unit is to be shut down for an extended period of time, it is necessary to re-flush the unit every three weeks OR to circulate a preservative solution through the membrane to prevent the growth of biological organisms. Use the following procedure to preserve the RO elements:

**PRESERVATIVE CHEMICAL #3 IS A FOOD GRADE PRESERVATIVE. SEE WARNING LABEL ON SIDE OF PACKAGE AND ADHERE TO ALL SAFETY PRECAUTIONS ON LABEL.**

**NOTE: You should allow your unit's product water to run to drain for the first 30 minutes after cleaning or upon start up after preservation.**

The procedure is the same than cleaning Step 1 to Step 6. Step 7 is to remove the cleaning filter and leave everything as it is until using the RO system again.

## **OIL CHANGE PROCEDURE**

An oil change is recommended after the first 50 hours of RO use. Subsequent oil changes are to be performed every 500-hour intervals OR changed annually. Change oil any time moisture is detected or if oil is cloudy. For additional pump information, refer to

**MANUFACTURER'S LITERATURE**

at the back of this manual.

**NOTE: The first oil change requires a complete oil drain, to ensure your pump is free of any fragments.**

**DO NOT RUN PUMP WITHOUT OIL IN THE CRANKCASE.**

**NOTE: Prior to the oil change, it MAY facilitate the oil replacement process by running the RO unit to heat the oil. Heating the oil reduces the viscosity allowing it to be more fluid to travel through the pump.**

## **Change of Membranes**

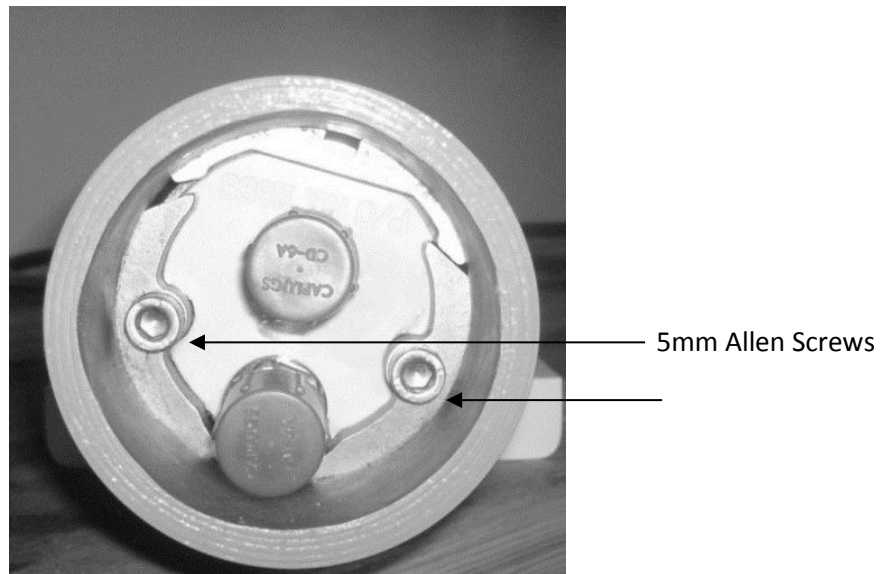

To change the membrane, start on the side, where the sea water is going into the membrane. This is normally the side, where the yellow spot on the PV is located. Turn out the 5mm Allen screws. Pull out the blocks which are fitted in groove of the PV. Now take two screwdrivers and place them under the HP stainless connection. Pull out the end cap.

Now you see the membrane inside. Pull the old membrane out. You see at the sea water side a seal on the membrane. The new membrane has to be installed similar.

Before installing the new membrane, lubricate everything with SILICON GREASE. Don't use any other lubricant. Any other lubricant will damage the membrane. Refer to the parts list to order the proper lubricant.

Push the new membrane into the PV and push the end cap in position.

Perform a leak test.







Manufactures Literature

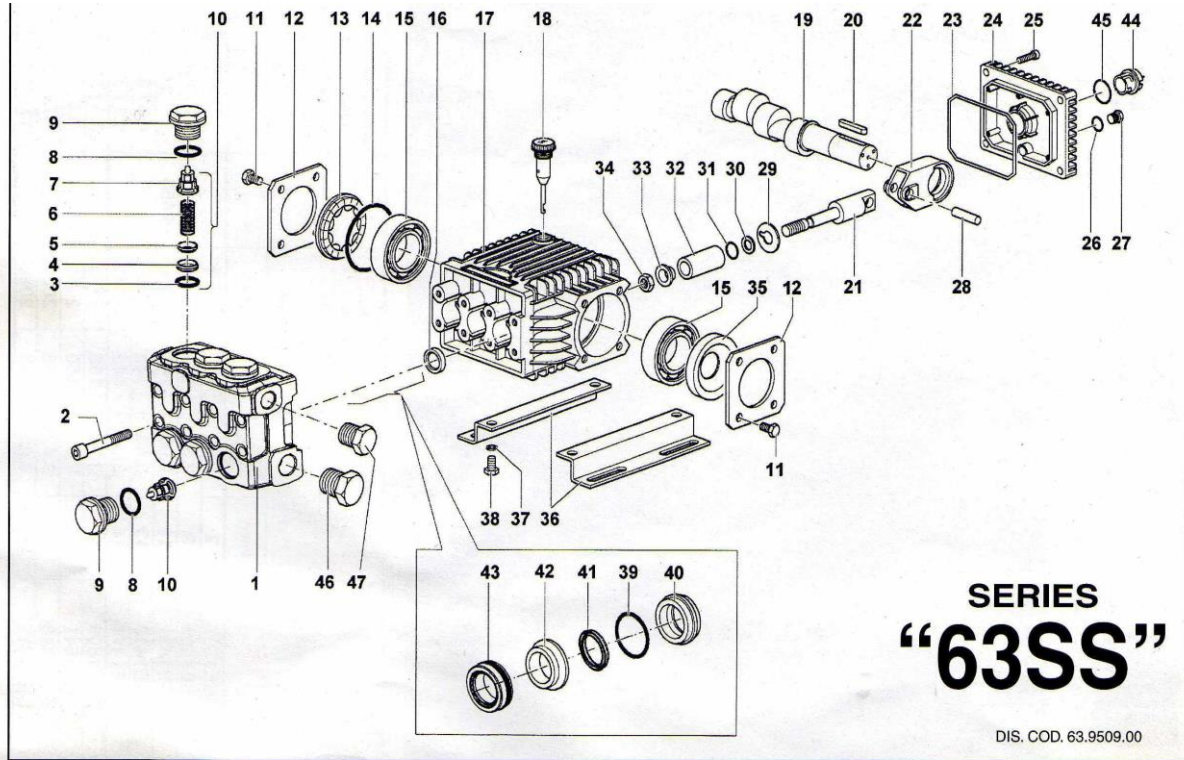

DIS. COD. 63.9509.00

KIT N.	PISTON - PISTONE Ø 15		PISTON - PISTONE Ø 18	
	KIT 159	KIT 192	KIT 214	KIT 215
Position included	16	3 - 4 - 5	41 - 43	39 - 40
Posizioni include		6 - 7 (10)		41 - 42 43
N. pcs.	3	6	3	1

**STANDARD  
VERSION  
-M-**

MODEL - MODELLO:
SSE1507 - SSE1509 SSU1509 - SSU1511
SSE1411 - SSE1413 - SSE1414 SSU1413 - SSU1415















**SSE 1507 - SSU 1509  
SSE 1509 - SSU 1511  
SSE 1411 - SSU 1413  
SSE 1413 - SSU 1415  
SSE 1414**

POS.	CODE CODICE	DESCRIZIONE DESCRIZIONE	N. PCS.
1	63.1216.36	Testata pistone Ø 15 INOX	1
	63.1219.36	Testata pistone Ø 18 INOX	1
2	99.3193.00	Vite M 8x65 UNI 5931 INOX	8
3	90.3841.00	OR Ø 17,13x2,62 (3068)	KIT 192 6
4	36.2036.66	Sede valvola - SS	KIT 192 6
5	36.2001.76	Valvola	KIT 192 6
6	94.7373.00	Molla Ø m. 9,4x14,8 - SS	KIT 192 6
7	36.2025.51	Guida valvola	KIT 192 6
8	90.3847.00	OR Ø 20,24x2,62 (3081)	6
9	98.2229.00	Tappo M 24x1,5x17 INOX	6
10	36.7130.01	Gruppo valvola - SS	KIT 192 6
11	99.1808.00	Vite M 6x10 UNI 5739 - INOX	8
12	63.1500.76	Coperchio laterale carter - INOX	2
13	44.2118.01	Distanziale con indicatore	1
14	90.4097.00	OR Ø 55,56x3,53 (159)	1
15	91.8331.00	Cuscinetto a sfere 6305	2
16	90.1595.00	Anello radiale Ø 18x26x6	KIT 159 1
17	63.0100.22	Carter	1
18	98.2103.00	Tappo carico olio G 3/8	1
	63.0212.65	Albero SSE1507 - SSE1411 - SSU1509 - SSU1413	1
	63.0216.65	Albero SSE1509 - SSE1413 - SSU1511 - SSU1415	1
	63.0218.65	Albero SSE1414	1
20	91.4892.00	Linguetta	1
21	63.0501.66	Guida pistone - SS	3
22	63.0300.22	Biella	3
23	90.3920.00	OR Ø 101,27x2,62 (3400)	1
24	63.1600.22	Coperchio posteriore carter	1
25	99.1838.00	Vite M 6x14 UNI 5931 - INOX	4

POS.	CODE CODICE	DESCRIZIONE DESCRIZIONE	N. PCS.
26	90.3585.00	OR Ø 10,82x1,78 (2043)	1
27	98.2040.00	Tappo G 1/4x9 - INOX	1
28	97.7335.00	Spinotto Ø 9x27,5	3
29	96.7076.00	Rosetta Ø 9x25x0,5 - INOX	3
30	90.5022.00	Anello antiest. Ø 6,2x9x1,5	3
31	90.3573.00	OR Ø 5,28x1,78 (2021)	3
	52.0400.09	Pistone Ø 15	3
	44.0401.09	Pistone Ø 18	3
33	63.2115.66	Rosetta Ø 8 con collare - INOX	3
34	92.2215.00	Dado M 8 - SS	3
35	90.1641.00	Anello radiale Ø 25x62x10	1
36	50.2000.74	Piedino	2
37	96.7016.00	Rosetta Ø 8,4 UNI 1751 zincata	4
38	99.3037.00	Vite M 8x16 UNI 5739 - 8.8 zincata	4
39	90.3608.00	OR Ø 28,30x1,78 (2112)	KIT 215-216 3
	63.0806.66	Anello di fondo Ø 15 - SS	KIT 215 3
	63.0807.66	Anello di fondo Ø 18 - SS	KIT 216 3
	90.2150.00	Anello ten. alt. Ø 15x19,5 L.P.	KIT 214-215 3
	90.2200.00	Anello ten. alt. Ø 18x22,5 L.P.	KIT 204-216 3
	63.2164.66	Anello intermedio Ø 15 - SS	KIT 215 3
	63.2165.66	Anello intermedio Ø 18 - SS	KIT 216 3
	90.2160.00	Anello ten. alt. Ø 15x24x8,5 H.P.	KIT 214-215 3
	90.2210.00	Anello ten. alt. Ø 18x28x10 H.P.	KIT 204-216 3
44	63.2100.51	Spia livello olio	1
45	90.4051.00	OR Ø 26,58x3,53 (4106)	1
46	98.2180.00	Tappo G 1/2x10 INOX	1
47	98.2100.66	Tappo G 3/8x13 INOX	1



Manufactures Literature

 <b>CHART OF COMPATIBLE MINERAL OILS</b> VERTÄGLICHE MINERAL ÖLE MARQUES D'HUILES MINÉRALES COMPATIBLES TABELLA DEGLI OLI MINERALI COMPATIBILI	
INTERPUMP	 X-9.9 = ORIGINAL =
AGIP	 F1 SUPERMOTOR OIL
BP	 VISCO 2000
CASTROL	 GTX3 MAGNATEC
ESSO	 UNIFLO
FIAT (FI)	 VS MAX
FINA	 DELTA SUPER
IP	 AZZURRO
MOBIL	 SUPER
Q8	 Q8 FORMULA RALLYE
ROLOIL	 SUPERMULTIGRADE
SHELL	 HELIX SUPER
TEXACO	 HAVOLINE PREMIUM 15W40
TOTAL	 QUARTZ 4000

≡ SAE 15W40 ≡

- OIL VISCOSITY AT AMBIENT TEMPERATURES FROM +14°F TO +104°F
- ÖLVISKOSITÄT BEI RAUMTEMPERATUREN ZWISCHEN -10°C UND +40°C
- VISCOSITÉ HUILE A TEMPERATURES AMBIANTES ENTRE -10°C ET +40°C
- VISCOSITÀ OLIO CON TEMPERATURA AMBIENTE DA -10°C A +40°C

Cod. 31.0072.03 - 12/05 - 50.000 De Pietri



rev. 1

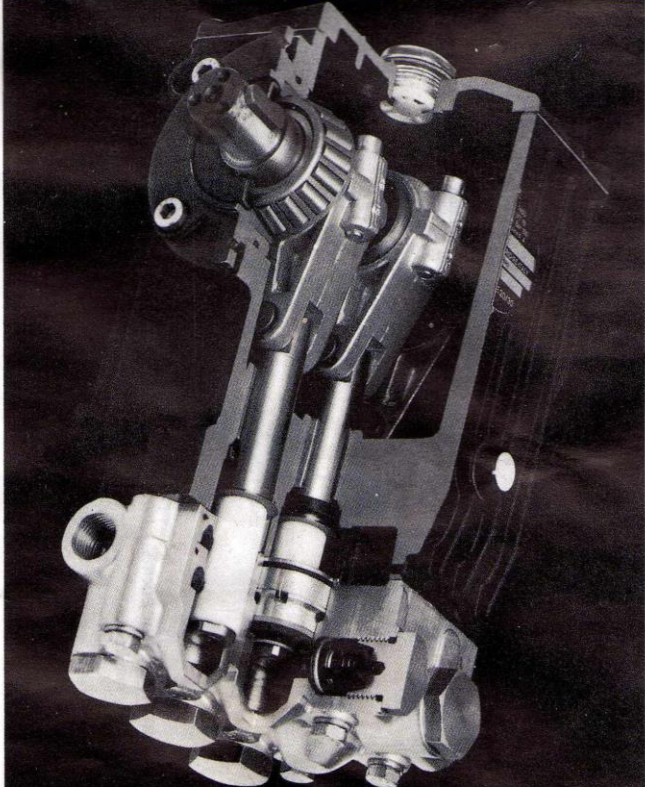





OPERATING INSTRUCTIONS  
GERAUCHSANSWEISUNG  
INSTRUCTIONS D'EMPLOI  
LIBRETTO D'ISTRUZIONI

**...TWO IMAGES OF A WORLD-LEADER GROUP**

**...DUE IMMAGINI DI UN GRUPPO LEADER NEL MONDO**

## Logbook

**Modell #** \_\_\_\_\_ **Serial Nr. #** \_\_\_\_\_

**Manufactures date** \_\_\_\_\_

Sea water temperature

Pressure

Product flow

Brine flow (over board)

Salinity Sea water

Salinity product water

PH Sea water

**Boostpump (LP Pump)**

The Fuse is mounted in the black box at the pump.

